

Series TLK

THERMOSTATIC EXPANSION VALVES FIXED ORIFICE, FIXED SUPERHEAT SETTING

PRODUCT DATA



Features

- Gas charge with MOP for quick response time adapted to small evaporators
- Wide evaporating temperature range
- Smallest dimensions
- Fixed superheat setting
- Warm thermal head provides best reliability
- Solder connections
- Internal pressure equalisation
- Extreme durable due to stainless steel head and stainless steel diaphragm welded using protective gas
- Fixed orifice
- Bypass on request
- Refrigerants: R134a, R22, 404A
Further refrigerants on request.

Specification

Nominal capacity range	0.5 to 3.9 kW R22
Evaporating temperature range	see table on page 2
Maximum pressure PS	29 bar
Maximum test pressure	32 bar
Max. ambient temperature	100 °C
Max. bulb temperature	140 °C
Static superheat	approx. 4 K
Length of capillary tube	1 m
Bulb diameter	12 mm

Application

Thermostatic expansion valves series TLK are used for serial produced systems such as drink dispensers, beer coolers, ice cream machines, milk cooling units, water chillers and vehicle air conditioning systems. For single injected evaporators.

Materials

Body	brass
Thermal head	stainless steel
Connection tubes	copper

Thermal Charges and Temperature Ranges

1. Gas charge with pressure limiting MOP

Refrigerant	Evaporation temperature range	MOP
R134a	+15 °C to -40 °C	MOP +15 °C
	+10 °C to -40 °C	MOP +10 °C
	±0 °C to -40 °C	MOP ±0 °C
R22	+15 °C to -45 °C	MOP +15 °C
	+10 °C to -45 °C	MOP +10 °C
	±0 °C to -45 °C	MOP ±0 °C
	-18 °C to -45 °C	MOP -18 °C
R404A	+10 °C to -50 °C	MOP +10 °C
	±0 °C to -50 °C	MOP ±0 °C
	-18 °C to -50 °C	MOP -18 °C
R407C	+15 °C to -30 °C	MOP +15 °C
	+10 °C to -30 °C	MOP +10 °C

MOP valves protect the compressor by limiting the increase of suction pressure.

The MOP value should be chosen for the max. permissible suction pressure of the compressor or min. 5 K higher than the required evaporating temperature of the system.

For orders without any MOP indication a valve with MOP + 10 °C will be delivered.

With gas charged valves and MOP it is under all operating conditions necessary that the bulb is always colder than the capillary tube and the thermal head!

With the Honeywell TLK series the thermal head is heated advantageously by the liquid refrigerant. The warm thermal head is on the safe side at any time.

Further refrigerants and MOP on request.

Capacities

Type	Orifice size	Nominal capacity (kW*)			
		R134a	R22	R404A	R407C
TLK	0.3	0.34	0.50	0.37	0.50
	0.5	0.65	1.0	0.70	1.0
	0.7	0.90	1.3	1.0	1.3
	1.0	1.3	1.9	1.5	1.9
	1.5	2.1	3.1	2.3	3.1
	2.0	2.7	3.9	2.9	3.9

* Capacities are based on $t_0 = -10\text{ °C}$, $t_c = +25\text{ °C}$ and 1 K subcooled liquid refrigerant entering the valve.

For other operating conditions see capacity charts in Honeywell catalogue or consult the Honeywell software.

Dimensions and Weights

Type	Orifice size	Connections		Weight (kg)
		Inlet (A)	Outlet (B)	
TLK	0.3	6 mm ODF	10 mm ODF	approx. 0.18
	0.5			
	0.7			
	1.0	1/4" ODF	3/8" ODF	
	1.5			
	2.0	10 mm ODF	12 mm ODF	
3/8" ODF		1/2" ODF		

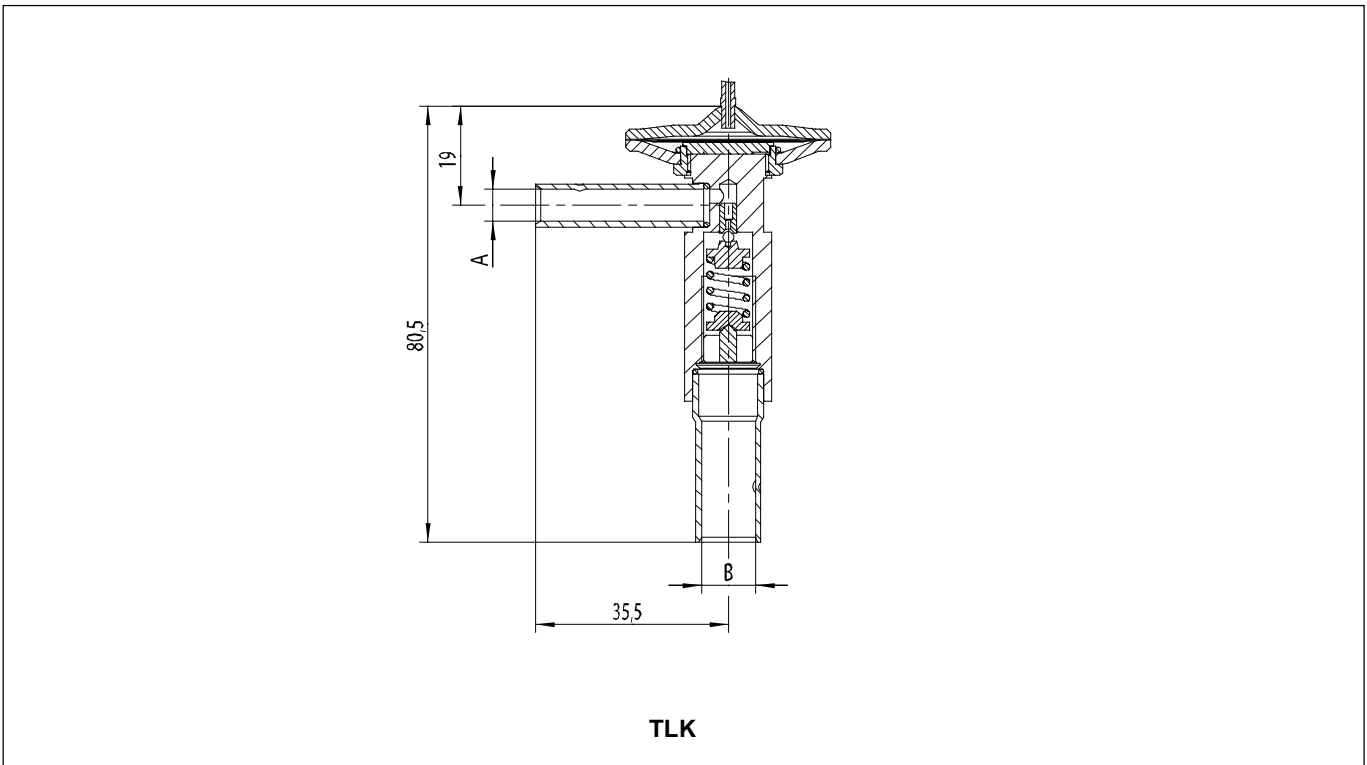

Type Code / Order Information

	TLK	0.5	R22	MOP +10 °C	6 mm x 10 mm
Series					
Orifice size					
Refrigerant					
Gas charge with MOP					
Solder connection ODF (inlet x outlet)					

Installation

- The valves may be installed in any position.
- The bulb should preferably be positioned on the upper half of a horizontal suction line but never after a liquid trap. As a general rule, bulbs of expansion valves should be insulated to prevent them being affected by the ambient temperature.
- In case of ice formation at the mounting site of the bulb, we advise to use a bulb clamp instead of clips.
- When soldering the valve, the valve body must not get warmer than 100 °C.
- Do not bend or squeeze the bulb.
- Constructive modifications at the valve are not allowed.

Information for original equipment manufacturers:
 The valve series TLK can be customised to the requirements of your series device in an optimum way. Contact us!

Honeywell

Automation and Control Solutions

Honeywell GmbH
Hardhofweg
74821 Mosbach/Germany
Phone: +49 (0) 62 61 / 81-475
Fax: +49 (0) 62 61 / 81-461
E-Mail: cooling.mosbach@honeywell.com
www.honeywell-cooling.com

Manufactured for and on behalf of the
Environment and Combustion Controls
Division of Honeywell Technologies Sàrl,
Ecublens, Route du Bois 37, Switzerland
by its authorised representative Honeywell GmbH